











ACCESSORIES

Mounting Accessories

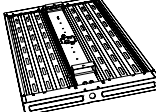
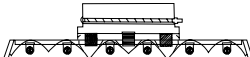
SURFACE MOUNT HANGERS

Surface Mount Hangers	Cat. No.	Description	For Use With
	ITB-4	Hanger for mounting close to ceiling on T-Bar grid system	All surface mounted fixtures
	CS-2	Ceiling spacer for mounting directly to outlet box. Used for mounting fixtures below combustible low density cellulose fiberboard ceilings. Maintains 1½" spacing.	All surface mounted fixtures
	CS-4	All purpose spacer (1½" × 2¼" × 4"), maintains 1" spacing on any type of installation	All surface mounted fixtures
	CS-5	All purpose spacer with special T-Bar clip and stud for mounting to an inverted T-Bar ceiling. Maintains 1½" spacing.	All surface mounted fixtures
	CSZT	Zip tee hanger 1½" spacer. Designed for 15/16" wide T-Bars.	CS and CSR series
	KZT	Zip tee hanger 1½" spacer. Designed for 15/16" wide T-Bars.	K, KL, KL-V, and KT
	CSTH	Slide tong hanger for ungrooved channel. Maintains 1½" spacing.	CS and CSR series
	KTH	Slide tong hanger with 7/8" hole. Maintains 1½" spacing.	K, KL, KL-V, and KT
	LHVTH	Slide tong hanger with 7/8" hole.	LHV
	LHSH6	Slide tong hanger with 5/16" holes	LHR 6-Lamp fixtures
	LHSH4	Slide tong hanger with 5/16" holes	LHR 4-Lamp fixtures
	PEBU	End surface mounting bracket for 2H3S hub options	LUN, LU, FNPS
	PEBUHMS	End surface mounting bracket for 2H and 2HS hub options	FNPV, FNPS
	PEBA	End surface mounting bracket with 90° adjustment for 2H3S hub options	LUN, LU, FNPS
	PEBAHMS	End surface mounting bracket with 90° adjustment for 2H and 2HS hub options	FNPV, FNPS
	PTBS	Surface mounting bracket, 304 Stainless steel, 2 brackets	FNPV, FNPS, FDPS, FNPH, FDPH
	PTBS3	Surface mounting bracket, 304 Stainless steel, 3 brackets	FNPV, FNPS, FDPS, FNPH, FDPH
	PTBA	Surface mounting bracket, 304 Stainless steel, wall mount with 90° adjustment in 15° increments, 2 brackets	FNPV, FNPS, FDPS, FNPH, FDPH
	PTBA3	Surface mounting bracket, 304 Stainless steel, wall mount with 90° adjustment in 15° increments, 3 brackets	FNPV, FNPS, FDPS, FNPH, FDPH
	FSPHB	Top bracket suspension kit, 304 Stainless Steel	FSPH
	FSPHWA	Top bracket wall/angle kit, 304 Stainless Steel	FSPH

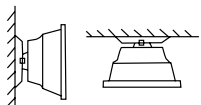
ACCESSORIES

Mounting Accessories

CHAIN AND CABLE HANGERS

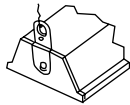
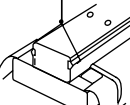
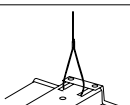
Chain and Cable Hangers	Cat. No.	Description	For Use With
	LUNHK	Chain hanging (chain not included)	LUN, LU
	SSHK	Stainless Steel hanging kit (chain not included)	LU
	CSHC	Chain hanging assembly includes two 24" lengths of chain and two hanger hooks.	CS and CSR
	KHC	Chain hanging assembly includes two 24" lengths of chain and two hanger hooks.	K, KL, KL-V, and KT
	ICHC	Chain hanger assembly, #3 size double loop chain, 12'.	IC
	GLH5 GLH10 GLH20	Cable hangers, #2 size cable with loop-end, 5', 10', and 20' lengths, adjustable	All industrials
	LHVQM5 LHVQM10 LHVQM20	Y-Fit Hook Cable Hangers, #2 size cable, 5', 10', and 20' lengths, adjustable	LHV
	CM24 CM48	Single point mount cable with canopy kit, pair. (Feed and non-feed ends) 24" or 48" with barrel adjuster.	STP. Others may require field drilling of mounting holes.



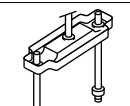
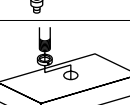
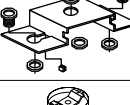

PENDANT/STEM MOUNTING ACCESSORIES

Pendant/Stem Mounting	Cat. No.	Description	For Use With
	HUBK	Stem hanging kit consists of two die cast hubs, two "O" rings and locknuts. Hubs are threaded for 1/2" pipe. Housings must be drilled to install hubs.	LUN, FNPV, LU, FNPS, FNPH, FDPH
	S18D	Double canopy (2) 18" stems	All 4' RO and PT
	SB3	Stem hanger adaptor bracket for 3-lamp surface mounted units. Reduces total number of mounting points required.	MWW 3-lamp EWW 3-lamp AWW 3-lamp WCW 3-lamp
	S18	Swivel canopy, one 18" stem - all white finish, 8° swivel	Individual or continuous row mounting of most surface and industrial fixtures
	SS18	Swivel canopy, one 18" stem - all white finish, 45° swivel	
	C18	Swivel canopy only - all white finish, 8° swivel	
	S018	One 18" stem only - all white finish	

ACCESSORIES

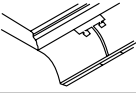
Industrial and Striplight Accessories

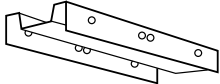
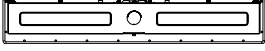
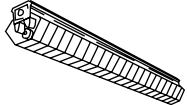
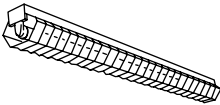
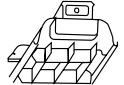
REFLECTOR ACCESSORIES AND WIREGUARDS

Chain Hangers	Cat. No.	Description	For Use With
	KLRAC	Full range aligners (set of two) for aligning reflector flanges and closing gaps between two reflectors. White	KL
	KLVRAC		KL-V
	KLEC	Reflector end closure (per end). Baked white enamel	KL and KL-V
	KC2	Heavy duty 10" sleeve coupler	K, KL, KL-V, KT and CSR (HO)
 LHVWG-6 shown	LHVWG-4	Wireguard, white, 4-lamp LHV	LHV 4-lamp
	LHVWG-6	Wireguard, white, 6-lamp LHV	LHV 6-lamp
	LHRWG4K	Wireguard, white, 4-lamp LHR	LHR 4-lamp
	LHRWG4K	Wireguard, white, 6-lamp LHR	LHR 6-lamp
	LHRNWG	Wireguard, white, LHR Narrow Body	LHR Narrow
	LHEMWG	Wireguard, chrome, LHEM fixtures	LHEM
	LHEWWG	Wireguard, chrome, LHEW fixtures	LHEW
	ICWG4	4 ft. Wireguard, white	IC
	KLWG4		KL
	CSRWG4-4PK		CSR
	CSRWG2-4PK	2 ft. Wireguard, chrome colored finish	CSR
	CSRWG3-4PK	3 ft. Wireguard, chrome colored finish	CSR
	CSWG2-24PK	2 ft. Wireguard, chrome colored finish	CS
	CSWG3-12PK	3 ft. Wireguard, chrome colored finish	CS
	CSWG4	4 ft. Wireguard, chrome colored finish	K, CS
	CHWG2-12PK	2 ft. Wireguard, chrome colored finish	CH
	CHWG3-12PK	3 ft. Wireguard, chrome colored finish	CH
	CHWG4-12PK	4 ft. Wireguard, chrome colored finish	CH
		KLEGG	Metal egg crate louver, 4 ft., White
Two required for 8 ft. fixtures			
	KLFA12	Framed acrylic shielding. Two required for 8 ft. units. Cannot be combined with the KSWG4	KL (not available with KL-V)

SENSOR ACCESSORIES FOR INDUSTRIAL AND STRIP FIXTURES¹



- Digital passive infrared (PIR) sensor
- Unique Smart Cycling™ for improved lamp life, dual output version only
- Single and dual timer operation
- Supports mounting heights up to 45 ft.
- Photosensor version available for daylight harvesting
- Kit includes "plug and play" wiring that enables use with standard fixtures



HIGH BAY, INDUSTRIAL AND STRIP FIXTURE ACCESSORY OFFERING (INCLUDES SNAP ON EXTENSION ADAPTOR*)

- OS1K Occupancy sensor kit, 120/277/347V, one relay
- OS2K Occupancy sensor kit, 120/277/347V, two relay
- OS480K Occupancy sensor kit, 480V, one relay
- ODS1K Occupancy sensor kit with daylight harvesting photosensor, 120/277/347V, one relay
- ODS2K Occupancy sensor kit with daylight harvesting photosensor, 120/277/347V, two relay
- ODS480 Occupancy sensor kit with daylight harvesting photosensor, 480V, one relay

*Extension adaptor needed when the height of the edge of the ballast cavity knockout is greater than or equal to 1.5" from bottom side of housing or reflector
 *Extension adaptor should be used to position the sensor below the bottom of the reflector for full field of view coverage

LHV SENSOR ACCESSORY OFFERING* (INCLUDES EASY TO INSTALL LHV SNAP ON BRACKET)

- LHVOS1 LHV Occupancy sensor kit, 120/277/347V, one relay
- LHVOS2 LHV Occupancy sensor kit, 120/277/347V, two relay
- LHVOS480 LHV Occupancy sensor kit, 480V, one relay
- LHVODS1 LHV Occupancy sensor kit with daylight harvesting photosensor, 120/277/347V, one relay
- LHVODS2 LHV Occupancy sensor kit with daylight harvesting photosensor, 120/277/347V, two relay
- LHVODS480 LHV Occupancy sensor kit with daylight harvesting photosensor, 480V, one relay

¹ Programmed start ballasts recommended for use with sensor accessories.

*Factory installed sensor options available with LHV fixture, see page 60.

REFLECTORS FOR CH 1-LAMP CHANNELS

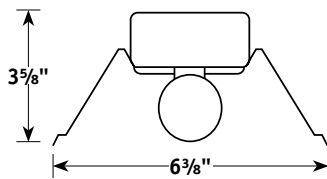

Symmetric

CHR2 Symmetric reflector for 2' fixtures.

CHR3 Symmetric reflector for 3' fixtures.

CHR4 Symmetric reflector for 4' fixtures

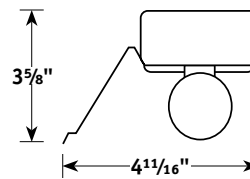

Asymmetric

CHRA2 Asymmetric reflector for 2' fixtures.

CHRA4 Asymmetric reflector for 4' fixtures.

CHR and CHRA reflectors are secured to channel with sheet metal screws provided.
CHR and CHRA reflectors are pre-finished with baked enamel, 86% minimum reflectance.
Polyester powder coat paint after fabrication (PAF) available as option.

REFLECTORS FOR CS AND K 1- OR 2-LAMP CHANNELS

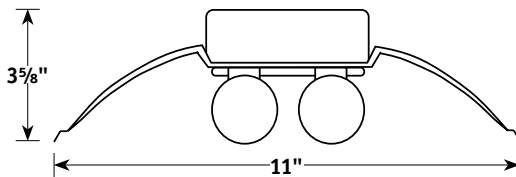

Symmetric - CSR4

Symmetric reflector for 4' fixtures (order two for 8' units).

Center saddles are required for 8' channels.

For CS channel order center saddle CSSAD.

For K channel order center saddle KSAD.

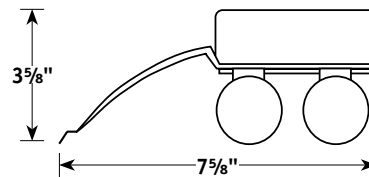

Asymmetric - CSRA4

Asymmetric reflector for 4' fixtures (order two for 8' units).

Center saddles are required for 8' channels.

For CS channel order center saddle CSSAD.

For K channel order center saddle KSAD.

CSR and CSRA reflectors are attached with captive quarter turn fasteners included.
CSR and CSRA reflectors are pre-finished with baked enamel, 86% minimum reflectance.
Polyester powder coat paint after fabrication (PAF) available as option.

REFLECTORS FOR SS 1 OR 2-LAMP STAGGERED STRIPS

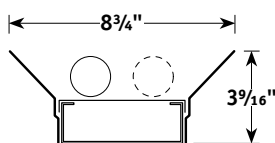

SSR

Symmetric
(2 pieces)

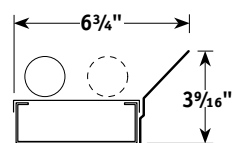

SSRA

Asymmetric
(1 piece)

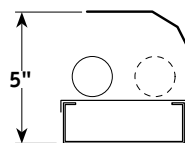

SSRAK

Asymmetric Kicker
(1 piece only)

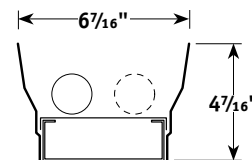

SSRD

Symmetric Deep
(2 pieces)

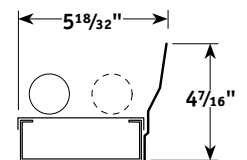

SSRDA

Asymmetric Deep
(1 piece)

Ordering Guide: Show reflector as option on strip catalog number. (Example: SS4-132SYM-EU-SSR)

Notes

1. Symmetric reflectors consist of two pieces.
2. Asymmetric reflectors consist of one piece.
3. Adjustable housings require 4' reflectors for field adjustment.
4. Use of reflector(s) on staggered strip requires modification to strip housing. Bulk reflectors should not be ordered except as replacements.
5. Reflectors attach with sheet metal screws, provided.

Reflectors are pre-finished with baked white enamel, 86% minimum reflectance.
Polyester powder coat paint after fabrication (PAF) available as option.

RECESSED OPTIONS

Air Handling

TECHNICAL

BASIC AIR FUNCTIONS

Designation	Description	Air Function
-S	Static	No air flows through fixture.
-A	Air Supply/Return	Air flows into room from plenum or back into plenum from room. We provide slots in housing. For optional vanes, see below.
-H	Heat Extract	Slots are provided in end cap or back of housing (instead of through black reveal). Units without a black reveal feature slots in door for air passage to lamp compartment. For optional dampers, see below.
-C	Combined	Both the -A and -H functions above are combined in one unit.

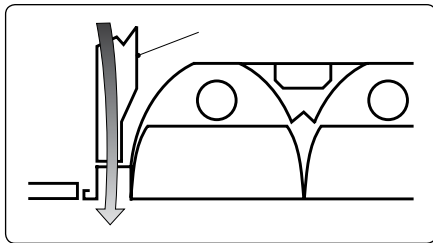

SUPPLY

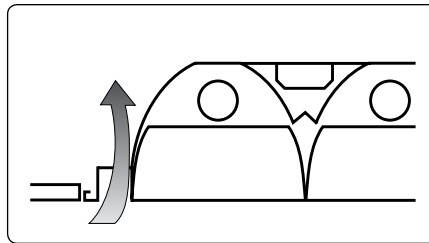

RETURN

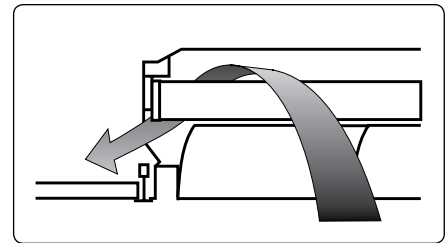

EXTRACT THROUGH END CAP

Note: Some units extract air through back of fixture housing.

AIR FUNCTION CONTROL OPTIONS

Vanes (V) Also referred to as *air pattern blades* or *directional air vanes*.

Vanes work with supply/return air (-A or -C). Vanes open outward, from 0 to 90 degrees, like a door swinging open. To control air flow, adjust opening as desired or close completely. When used on a -C fixture, vanes operate independently of dampers.

Dampers (D) Also referred to as *heat removal dampers* or *control dampers*.

Dampers work with extract air (-H, -C). Dampers slide open, like a window. To control air flow, adjust opening as desired or close entirely. When used on a -C fixture, dampers are controlled independently of vanes.

Designation	Description
-AV	Air Supply/Return with Vanes
-CV	Combined with Vanes Only
-CVD	Combined with Vanes and Dampers

Designation	Description
-HD	Heat Extract with Dampers
-CD	Combined with Dampers Only

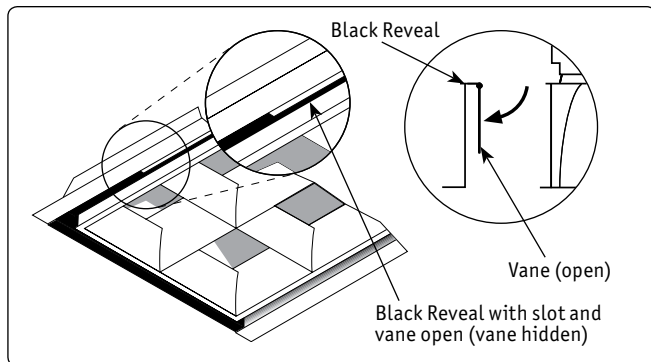

AIR WITH VANES (SUPPLY/RETURN OPTIONS)

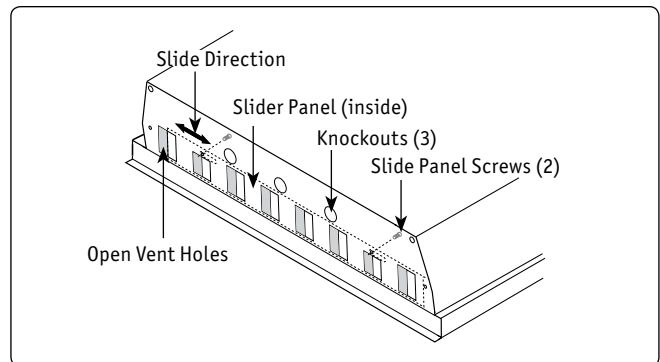

DAMPERS (EXTRACT OPTION)

RECESSED OPTIONS

Ceiling Trims

TECHNICAL

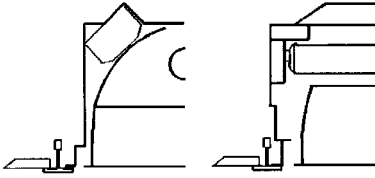
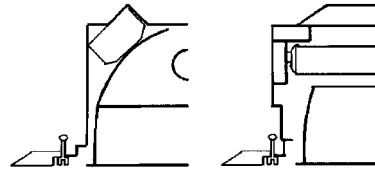
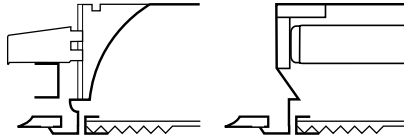
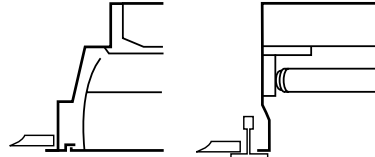
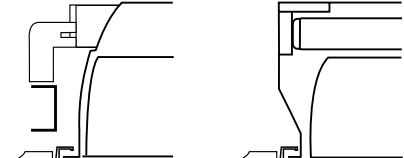
Ceiling Type	Recommended Trim	Cross Section	Availability
1" T-Bar	G (Grid)	 <p>For lay-in installation in exposed grid ceilings. Maximum tee widths of 1" and maximum tee heights of 1½" allowed.</p>	45, 4PS, 4VS, 5PA, AC, BR, CRC, CRF, CRS, EMI, EMSE, EMX, EPC, FW, HC, HH, HV, JT8, STE, STEL, STS, STSL, TRA, VC, VHC, WT, ZPT
¼" Slot Grid	SG (Slot Grid)	 <p>For slot grid type ceilings with nominal ¼" face and ⅜" tall shoulder, louver will be level with the ceiling plane.</p>	45, 5PA, BR, HC, P4, PW, STS, STSL
Hard Ceiling	F (Flange)	 <p>For tile, plaster, or plasterboard type ceilings. Overlapping extruded aluminum trim conceals edges of ceiling opening. Wing hanger suspension system included. Designate INT (intermediate) or EOR (end of row) for fixtures in row applications.</p>	45, 4PS, 4VS, 5PA, AC, CRC, CRS, HC, HH, HV, HZ, LHG, M46, P2, P4, ST8, VHC, WT NP and CRC series flange use yoke hanging system (not illustrated).
1" Tee across fixture ends. Supplied side trim support ceiling tile along length	GT (Integral Cross -tee)	 <p>For lay-in installation in grid ceilings. Fixture mounts on exposed tees at ends of fixture. Sides act as integral cross-tee to support tile, eliminating need for intermediary tees. Designed for nominal 1" tees.</p>	4594, BR04, NP, PVHC94, VHC94
Metal Pan	M (Modular)	 <p>For metal pan ceilings "Fit-in" style extruded trim aligns with modular tile joints. Fixture is supported from concealed suspension and includes all adjustable wing hangers.</p>	45, 4PS, 4VS, 5PA, HC, LHG, P2, P4

Recessed units available for Surface Mount (SM) applications:
45, 4PS, BR, CRS, EMS, EPC, FW, HC, JT8, LHG, LSL, PW, SER, STE, STEL, STS, STSL, VHC, ZPT. Refer to ordering guide to build.

RECESSED OPTIONS

Flange Trims

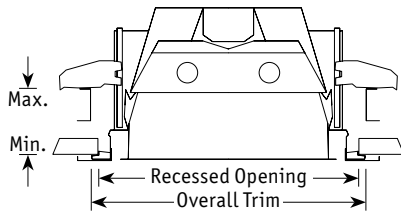

DIMENSIONAL EXAMPLE

PARABOLICS

		Rough-In Dimensions										
		Specify option INT (intermediate) or EOR (end of row).										
Series	Size	Vertical Wing Hanger Adjust		Overall Trim Dimensions		Single or Row	Single Unit	Row Length				
		Min.	Max.	Width	Length			Width	Length	Nom. Length	Multiply by	Plus
P4, HC	1' x 4'	1 1/4"	4 1/4"	12 13/16"	48 13/16"	12 1/8"	48 1/8"	48"	# in row	1/8"	(48" x 2) + 1/8" = 96 1/8"	
	2' x 2'	1"	3 7/8"	24 13/16"	24 13/16"	24 1/8"	24 1/8"	24"	# in row	1/8"	(24" x 2) + 1/8" = 48 1/8"	
	2' x 4'	1"	3 7/8"	24 13/16"	48 13/16"	24 1/8"	48 1/8"	48"	# in row	1/8"	(48" x 2) + 1/8" = 96 1/8"	
45	1' x 4'	1"	3 1/4"	12 13/16"	48 13/16"	12 1/8"	48 1/8"	48"	# in row	1/8"	(48" x 2) + 1/8" = 96 1/8"	
	2' x 2'	1"	3 7/8"	24 13/16"	24 13/16"	24 1/8"	24 1/8"	24"	# in row	1/8"	(24" x 2) + 1/8" = 48 1/8"	
	2' x 4'	1"	3 7/8"	24 13/16"	48 13/16"	24 1/8"	48 1/8"	48"	# in row	1/8"	(48" x 2) + 1/8" = 96 1/8"	
VHC, PVHC	9" x 4'	2"	4"	10 1/2"	48 3/4"	9 7/8"	48 1/8"	48"	# in row	1/8"	(48" x 2) + 1/8" = 96 1/8"	

LENSED TROFFERS

		Rough-In Dimensions										
		Specify option INT (intermediate) or EOR (end of row).										
Series	Size	Vertical Wing Hanger Adjust		Overall Trim Dimensions		Single or Row	Single Unit	Row Length				
		Min.	Max.	Width	Length			Width	Length	Nom. Length	Multiply by	Plus
4PS, 4VS	1' x 4'	7/8"	3"	12 3/4"	48 3/4"	12 1/8"	48 1/8"	48"	# in row	1/8"	(48" x 2) + 1/8" = 96 1/8"	
	2' x 2'	1"	2 7/8"	24 3/4"	24 1/4"	24 1/8"	24 1/8"	24"	# in row	1/8"	(24" x 2) + 1/8" = 48 1/8"	
	2' x 4'	1"	2 7/8"	24 3/4"	48 3/4"	24 1/8"	48 1/8"	48"	# in row	1/8"	(48" x 2) + 1/8" = 96 1/8"	
5PA	1' x 4'	7/8"	3"	12 3/4"	48 3/4"	12 1/8"	48 1/8"	48"	# in row	1/8"	(48" x 2) + 1/8" = 96 1/8"	
	2' x 2'	1 1/4"	2 7/8"	24 3/4"	24 1/4"	24 1/8"	24 1/8"	24"	# in row	1/8"	(24" x 2) + 1/8" = 48 1/8"	
	2' x 4'	1"	2 7/8"	24 3/4"	48 3/4"	24 1/8"	48 1/8"	48"	# in row	1/8"	(48" x 2) + 1/8" = 96 1/8"	
ST8, WT	1' x 4'	1"	3 3/16"	12 3/4"	49 5/8"	12 1/8"	48 1/8"	48"	# in row	1/8"	(48" x 2) + 1/8" = 96 1/8"	
	2' x 2'	1"	3 3/16"	24 3/4"	24 5/8"	24 1/8"	24 1/8"	24"	# in row	1/8"	(24" x 2) + 1/8" = 48 1/8"	
	2' x 4'	1"	3 3/16"	24 3/4"	49 5/8"	24 1/8"	48 1/8"	48"	# in row	1/8"	(48" x 2) + 1/8" = 96 1/8"	
CRS (FA Door)	1' x 4'	1 3/4"	4 1/2"	12 15/16"	49 11/16"	11 1/4"	48 1/4"	48"	# in row	1/8"	(48" x 2) + 1/8" = 96 1/8"	
	2' x 2'	1 3/4"	4 1/2"	24 15/16"	24 3/4"	23 1/4"	24 1/4"	24"	# in row	1/8"	(24" x 2) + 1/8" = 48 1/8"	
	2' x 4'	1 3/4"	4 1/2"	24 15/16"	49 11/16"	23 1/4"	48 1/4"	48"	# in row	1/8"	(48" x 2) + 1/8" = 96 1/8"	
CRS (FCS & FSS Door)	1' x 4'	1 3/4"	4 1/2"	12 11/16"	48 7/8"	12"	48 1/4"	48"	# in row	1/8"	(48" x 2) + 1/8" = 96 1/8"	
	2' x 2'	1 3/4"	4 1/2"	24 11/16"	24 7/8"	24"	24 1/4"	24"	# in row	1/8"	(24" x 2) + 1/8" = 48 1/8"	
	2' x 4'	1 3/4"	4 1/2"	24 11/16"	48 7/8"	24"	48 1/4"	48"	# in row	1/8"	(48" x 2) + 1/8" = 96 1/8"	
CRC	1' x 4'	3 5/8"	4 1/8"	12 3/4"	48 3/4"	12"	48"	48"	# in row	1/8"	(48" x 2) + 1/8" = 96 1/8"	
	2' x 2'	3 5/8"	4 1/8"	24 3/4"	24 3/4"	24 1/8"	24 1/8"	24"	# in row	1/8"	(24" x 2) + 1/8" = 48 1/8"	
	2' x 4'	3 5/8"	4 1/8"	24 3/4"	48 3/4"	24 1/8"	48 1/8"	48"	# in row	1/8"	(48" x 2) + 1/8" = 96 1/8"	

RECESSED ACCESSORIES

Flange Kit and Plaster Frame Information

FLANGE KITS

Flange kits are extruded aluminum frames that act as individual fixture T-Bar frames to support the weight of any G (grid) trim recessed fixture in drywall or plaster ceilings. Kits snap together without the use of tools (18 gauge galvanized corner clips provided) and are hung by tie wire (by others) from the ceiling support structure.

From the room side flange kits mimic the appearance of T-Bars in a baked white enamel finish. Consult chart for ceiling cut out dimension.

For continuous row applications order flange kits plus one FKCR, continuous row flange connector kit, for each joint between fixtures. (One less than the number of fixtures in the row.)

FLANGE KIT		CEILING OPENING	
Catalog No.	Size	Width	Length
FK14	1' × 4'	12 ³ / ₈ "	48 ³ / ₈ "
FK22	2' × 2'	24 ³ / ₈ "	24 ³ / ₈ "
FK24	2' × 4'	24 ³ / ₈ "	48 ³ / ₈ "
FK44	4' × 4'	48 ³ / ₈ "	48 ³ / ₈ "
FK81	8" × 1'	8 ³ / ₈ "	12 ³ / ₈ "
FK82	8" × 2'	8 ³ / ₈ "	24 ³ / ₈ "
FK84	8" × 4'	8 ³ / ₈ "	48 ³ / ₈ "

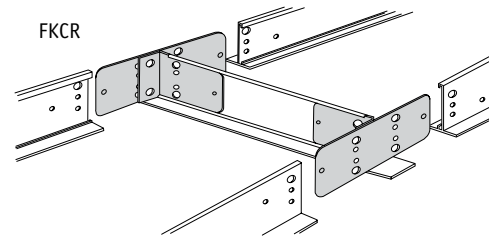

FLANGE KIT INSTALLATION INSTRUCTIONS

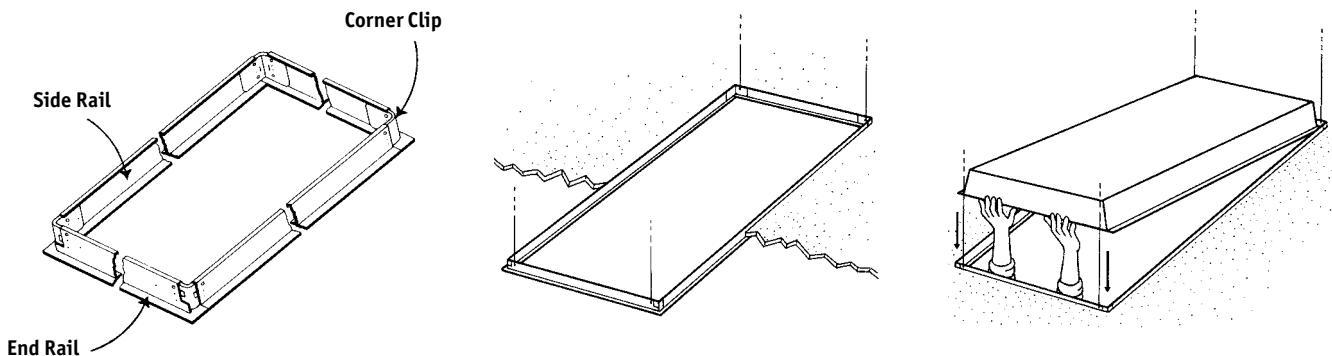

1. Cut ceiling opening to proper dimensions. Slip fit corner clips into side and end rails. No tools are required.
2. Place Flange Kit in ceiling opening and wire each corner to ceiling structure. Pull up tight against ceiling.
3. Place grid trim troffer in Flange Kit.

PLASTER FRAMES

Plaster frames are galvanized steel rails used to trim ceiling openings primarily in wet plaster applications. They are installed during ceiling construction and help maintain the correct opening dimensions for installation of flange ST8 trimmed recessed fixtures. See fixture specification sheet for dimensions required for framing to support the weight of the fixture.

Use plaster inside dimensions for framing opening in dry ceilings.

Framing (by others) required to support the weight of the fixture.

Catalog No.	Description	Nominal Size	Inside Dimension
PL14	Individual	1' × 4'	12" × 48 ⁷ / ₈ "
PL14R	For Rows	1' × 4'	-
PL22	Individual	2' × 2'	24" × 24 ⁷ / ₈ "
PL24	Individual	2' × 4'	24" × 48 ⁷ / ₈ "
PL24R	For Rows	2' × 4'	-
PL44	Individual	4' × 4'	48" × 48 ⁷ / ₈ "

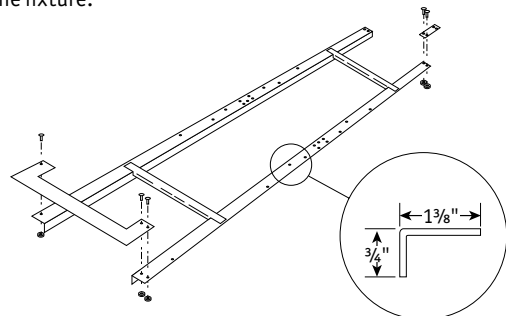

Plaster Frames:

- For mounting any Columbia Lighting flanged troffer in a plaster ceiling
- Provides a clean, finished appearance

STANDARDS COMPLIANCE

HOW TO ACHIEVE A FIRE RATING

UL publishes a book called The Fire Resistance Directory each February. A supplement is issued each August. The Fire Resistance Directory contains instructions for fire rated ceiling systems. Each approved ceiling system has a design number. The fire rated ceiling system is achieved by selecting a design number and following instructions, which include spacing criteria, enclosure requirements, and so on. When complete, the system carries a rating (for example: one hour). FR option provides a label indicating the fixture is suitable for use in such ceiling systems. Many ceiling designs required an enclosure or "tent" of fire resistant material over the back of the fixtures. These enclosures are either built on-site, sometimes of ceiling tile material, or purchased as one-piece molded covers.

Fire Rated Troffers: Debunking the Myth

WHAT IS A FIRE RATED LABEL?

Columbia Lighting can provide a fire rated label (FR option) which states that our recessed light fixtures are manufactured in accordance with UL1598 and, therefore, can be installed in a fire rated ceiling system. There are no additional requirements of a recessed fixture in order for it to be used in a fire rated design.

I NEED A FIRE RATED TROFFER.

A true fire rated troffer does not exist because UL does not list troffers as "fire rated". Instead, they list ceiling systems which may include UL listed troffers as part of that system.

BUT MY INSPECTOR SAYS I NEED ONE.

Your inspector has authority and jurisdiction over your project. However, a better understanding of the fire rated ceiling system process can help in your discussions. Order the FR option where required by local authorities.

I REMEMBER FIRE RATED TROFFERS FROM JOBS PAST.

UL listed three ceiling designs using a special fire rated troffer many years ago. Columbia Lighting (and a few others) offered this troffer, which consisted of a recessed unit with a sheet of fire resistant material attached to the back of it. Since all three ceilings have been obsolete for decades (some exceptions in Canada), Columbia Lighting no longer manufactures this troffer. Instead, we manufacture in accordance with UL 1598, which allows our recessed fixtures to be installed in a fire rated ceiling system.

FIRE RATED ENCLOSURES

An FR label does not indicate whether or not "tenting" of the fixtures is required; all installation must be in accordance with the UL Fire Rated Ceiling design.

T-BAR LOCK CLIPS

Four integral T-Bar lock clips are standard on many Columbia Lighting recessed fixtures. Integral clips are built according to the rigorous demands of UL 1598. Where integral clips are not available, a parts bag is provided containing two clips for attachment to the housing structure. Four clips are available upon request.

INTEGRAL CLIP

Fixture is equipped with integral T-Bar Clips at each end. To engage T-Bar, bend clip outward and lock under T-Bar.

For installation in the following NEMA ceiling types: -G -GR -NFG -NFSG -SS

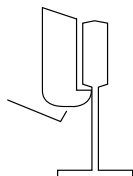

NON-INTEGRAL CLIP

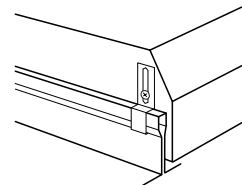

Fire Rated Label

This fixture is equipped with premium low heat ballasts to prevent ballast cycling when installed in a fire rated ceiling system. This fixture is compatible with UL Fire Rated Ceiling designs when installed in accordance with the UL Fire Resistance Directory.

DAMP AND WET LOCATION LABELS

Columbia fixtures will be labeled suitable for installation in damp locations (most fixtures) or wet locations (select extreme environment and outdoor fixtures) as called out on the specification sheets. Installation of a dry-location listed customer specified component such as an emergency inverter requires the fixture to be labeled for dry location use only.

BALLAST DISCONNECT

All Columbia fixtures are in compliance with NEC and CEC requirements for ballast disconnects by including integral ballast disconnects in required fixtures.

The following fixtures are excluded from the ballast disconnect requirement:

- Hazardous location fixtures—HZ, FNPH, FDPH, FSPH, CRS (with D2 option)
- Fixtures with emergency battery pack options

CIRCLE I UL STANDARD 1958

All Columbia fixtures are in compliance with UL Standard 1958, Clause 8.8.1, which reads as follows:

"A luminaire with instant-start ballast(s), incorporating bi-pin lampholders shall:

- a) Be constructed with a ballast(s) identified as Type CC, or
- b) Be constructed with lampholder intended for use with instant-start ballasts in accordance with Clause 4.1. Lampholders marked with a circle "I" comply with these requirements."

BALLAST OPTIONS

Ballast Types

BALLAST TYPES

Columbia Lighting supplies ballasts from a variety of reputable vendors whose products conform to Columbia Lighting's standard specifications (pg. 107). See Ballast Specified Vendor Options to order a particular manufacturer's product or ballast series. All ballast information is based on manufacturer's published literature and is subject to change without notice.

ELECTRONIC BALLAST TYPES

Start Method	Definition	Designation	Characteristics
Electronic Instant Start	Strikes lamp without filament preheating. Lowest wattage draw option for applications without control systems. Used for T8 bi-pin and slimline lamp types. Ballasts for F32T8 full or reduced wattage lamps are NEMA Premium qualified.	E	Standard (.87-1.0 BF)
		E104	EnergyMax 1.04 BF
		EHL	High light output (1.18-1.2 BF)
		ELW	Low wattage (.77-.78 BF)
		ETT	Twin Tube lamp types
Electronic Programmed Start	Recommended for frequently switched applications including occupancy sensor controlled lighting because programmed filament preheating can help extend lamp life. Remote mounting distance more restricted than with instant start. Sometimes called programmed rapid start. Available for all 2-pin lamp types. Ballasts for F32T8 full or reduced wattage lamps are NEMA Premium qualified and parallel wired.	EP	Standard, 0.88 BF
		EPTT	Twin Tube lamp types
		EP_	Alternate ballast factors. Eg. EP95, EP115 for T5 lamp types, EP104 for T8 lamp types
		EPHL	High light output (1.15 - 1.20 ballast factor)
		EPSP5	Parallel Wired for T5 lamps
Electronic Step Dimming	Electronic programmed start ballast with two hot leads to allow both lamps to switching between 100% and 50% light levels for energy management. Requires two switched leads from same panel. Not suitable for remote mounting. 2-lamp ballasts.	ESD	Standard BF (T5 or T8 bi-pin)
		ESD104	EnergyMax 1.04 BF (T8 Bi-pin)
		ESD80	Alternate ballast factor for 54T5H0
Electronic Full Dimming	Responds to either line voltage or low voltage signals to dim lamps from 100% to 10% or lower, depending on model. Many ED ballast types require voltage specified. Not suitable for remote mounting.	ED_	Add vendor and ballast series compatible with control system. Eg. ED120 LUTEC10

MAGNETIC BALLAST TYPES

Start Method	Definition	Designation	Characteristics
Low Power Factor	Also called normal power factor (NPF). Labeled for residential use only.	L	For residential fixtures using 2', 3', or 4' Bi-pin T12 lamp types.

BALLAST OPTIONS

Ballast Quantities and Specified Vendors

BALLAST QUANTITIES





Fixtures with 3, 4, 6, and 8 lamps will be supplied with two ballasts standard. Optional ballast quantities are available.

See also Master-Satellite option for ballast quantity options on tandem-wired pairs. In tandem-length fixtures with more than one ballast, lamps are wired side by side unless left and right (LR option) is specified.

Number of Lamps in Fixture	Standard Designation	Optional Ballast Designation
1 or 2	Provides one ballast	Adding 11, such as 11E or 11EP, provides two (2) ballasts in 2-lamp fixtures
3	Provides two ballasts, one on inboard lamp, one on outboard	Adding 3, such as 3E or 3EP, provides one (1) 3-lamp ballast
4	Provides two ballasts, one on inboard lamps, one on outboard	Adding 4, such as 4E or 4EP, provides one (1) 4-lamp ballast
6	Must specify	Adding 24 (eg.), such as 24E or 24EP, provides a 2-lamp and 4-lamp ballast (recommended). 3E or 3EP provides (2) 3-lamp ballasts
8	4E provides two (2) 4-lamp ballasts wired on lamps 1, 4, 5, 8 and 2, 3, 6, 7	Consult factory

SPECIFIED VENDORS*

Specify ballast type, optional ballast quantity and vendor option. Eg. 3EDULUTEHD

Vendor	Vendor Specified Designation	Vendor and Series Specified Designation	Vendor's Series Name (normal ballast factor unless noted)
	LUT	LUTHIL	Hi-Lume Dimming
		LUTES	EcoSystem incl. E1/E2 only (Dimming)
		LUTESSW	EcoSystem incl. sensor wires (Dimming)
		LUTEHD	EcoSystem H
	ULT	ULTHE	Ultim8
		ULTHP	High Performance
	GE	GEMAXH	Ultramax High BF
		GEMAXL	Ultramax Low BF
		GEMAXN	Ultramax
	SYL	SYLQHE	High Efficiency
		SYLPSX	Extreme
		SYLPHO	Helios Dimming
		SYLDIM	Powersense Dimming
	ADV	ADVCE	Centium
		ADVIO	Optanium
		ADVCM10	Mark X Dimming
		ADVCM7	Mark VII Dimming

*Others available, call out ballast catalog number in fixture description. Dimming ballasts use ED plus voltage and vendor designation.

BALLAST OPTIONS

Ballast Characteristics and Total System Watts

BALLAST CHARACTERISTICS

General Definitions

POWER FACTOR

Measure of how effectively ballast converts power source into usable watts. Ideal power factor would measure 1.0.

CREST FACTOR

Measure specifying the ratio of peak current to R.M.S. current in the waveform used to drive programmed start lamps. High crest factors shorten lamp life.

TOTAL HARMONIC DISTORTION

Measure of magnitude of input current harmonics compared with amplitude of fundamental frequency current.

BALLAST FACTOR

Lamp manufacturers publish lumen data based upon a “reference ballast” built to meet ANSI standards. Ballast factor is a measure of how well a ballast performs in comparison to the “reference ballast” as a percentage of rated lumen output.

COLUMBIA LIGHTING BALLAST SPECIFICATIONS

All factory-choice normal ballast factor electronic ballasts meet the following specifications. Optional ballast factors and customer specified vendor available as options.

Ballast must be high power factor, (min. 95), Class P, UL listed, meet IEEE and ANSI requirements C62 .41 Category A for transient protection and FCC Regulations, Class A for electromagnetic interference. Operates at voltage variance of +/- 10%, crest factor of <1.7, total harmonic distortion (THC) <10% for primary lamp type, minimum ballast factor (BF) of .87 (.95 for T5/T5HO lamp types). Ballast must start lamps at 0°F ambient temperature.

NEMA Premium All ballasts for F32T8 full and reduced wattage lamps must be NEMA premium qualified.

TOTAL SYSTEM WATTS

The Total System Watts refer to the ballast and lamp watts consumed per luminaire. Input watts are based upon ANSI watts as published by ballast manufacturer’s literature which is subject to change without notice. Ballast information shown is generic and serves as an approximation only; actual input watts vary according to specific ballast manufacturer and ballast number. For exact input wattage contact either the ballast manufacturer or Columbia Lighting Technical Support. Wattage published in Columbia IES photometric tests represents actual measured watts.

Total System Watts (Watts/Volts = Amps)

Ballast Type	Catalog Designation	Lamp Type	No. of Lamps	Input Watts*
Electronic Programmed Start T5	EP	F14/T5	1	19
	EP	F14/T5	2	34
	EP	F24/T5HO	1	28
	EP	F24/T5HO	2	53
	EP	F28/T5	1	34
	EP	F28/T5	2	66
	EP	F54/T5HO	1	63
	EP	F54/T5HO	2	121
	3EP	F54/T5HO	3	182
	4EP	F54/T5HO	4	240
	EP80	F54/T5HO	2	96
	EP95	F28/T5	2	60
	EP115	F28/T5	2	69
	ESD80	F54/T5HO	2	96/52
	ESD95	F28/T5	2	60/28
	ESD104	F32/T8	2	65/32.5
ESD115	F28/T5	1, 2	71/34	
Electronic Programmed Start T8	EP	F32/T8	1	31
	EP	F32/T8	2	62
	EP104	F32/T8	2	65
	3EP	F32/T8	3	92
	4EP	F32/T8	4	119

Ballast Type	Catalog Designation	Lamp Type	No. of Lamps	Input Watts*
Electronic Instant Start T8	E	F32/T8	1	30
	E	F32/T8	2	56
	3E	F32/T8	3	85
	4E	F32/T8	4	112
	E	F96/T8	1	70
	E	F96/T8	2	108
	E	F96/H0/T8	1	100
	E	F96/H0/T8	2	185
	E104	F32/T8	2	67/66
	E104	F32/T8 (28 watt)	2	60/59
	E105	F32/T8 (25 watt)	2	51/51
Electronic T12	E	F96/T12/ES	1	64
	E	F96/T12/ES	2	105
	EP	F96/T12/H0	1	119
	EP	F96/T12/H0	2	208
Electronic TT	ETT	F40/TT	1	39
	ETT	F40/TT	2	68
	3ETT	F40/TT	3	99
	EPTT	F40TT	1	38
	EPTT	F40TT	2	76
	3EPTT	F40TT	3	110

*Where published input watts differ between 120/277V the higher (120V) wattage is given. For 2 level step dim ballasts (ESD types) both high and low output wattages are given.

ELECTRICAL OPTIONS

EMERGENCY BATTERY PACKS INSTALLED

Luminaires with factory installed battery packs will bear the UL Emergency equipment label. Dry location labeling standard. Standard inverter options below are not suitable for cold temperature starting, damp or wet location labeling. Optional inverters available for these applications. Consult factory or specify vendor's catalog number.

EL	350-450 lumens for one 2'-4' lamp (T8, T12, U-Bent, TT)	EL141	1100-1400 lumens for one 2'-8' lamp (T8, T12, U-Bent, TT)
EL61	500-600 lumens for one 2'-4' lamp (T8, T12, U-Bent, TT)	EL142	1100-1400 total lumens for two 2'-4' lamps
EL71	600-700 lumens for one 2'-8' lamp (T8, T12, U-Bent, TT)	EL5*	390-700 lumens for one 2'-4' T5/T5HO
EL72	600-700 total lumens for two 2'-8' lamps (T8, T12, U-Bent)	EL5H*	725-1250 lumens for one 2'-4' T5/T5HO

*These inverters not available in some 2' fixtures due to space constraints. Remote mounting using accessory enclosure (by others) recommended.

FUSING





Fusing is available on all fixtures to prevent over current from being transmitted upstream through the fixture as may be possible due to a dead short fault in a ballast. Specify GLR (fast blow) or GMF (slow blow) fusing options. Fuses are not UL listed to break under load and therefore are not a substitute for the in-fixture ballast disconnects supplied standard where required by the National Electric Code.

FIXTURE FLEX AND LEADS

Fixture flex (also called pre-wire or whip) is a UL listed lighting component for recessed fixtures to provide the electrical wiring between the junction box and recessed fixture. Flex may be no longer than 6'. Typical cables use 3/8" flexible conduit and three or four 18 gauge leads. Flex cables are shipped pre-wired to the recessed fixture. Add option designation to catalog number after ballast options. Eg. C388

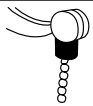
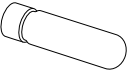
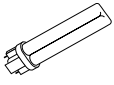
CABLE	NO. OF WIRES	CABLE DIAMETER	WIRE GAUGE
C Cable	3 3	8 3/8"	8 18 gauge
	4 4	2 1/2"	4 14 gauge
	5 5		2 12 gauge

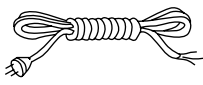
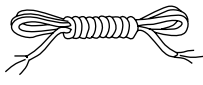
MISCELLANEOUS FIXTURES AND ELECTRICAL OPTIONS (ADD AS SUFFIX ON END OF CATALOG STRING)

Fixture/Option	Cat. No.	Description	For Use With
	PSW	Pull switch, one circuit, 120V only	Selected strips, surface units and industrials. Contact factory for applications
	PSWD	Pull switch, wired to the downlight circuit on a two circuit unit, 120V only	
	4PSW	Four-way pull switch for two circuit, two lamp unit, 120V only	
	NL	Medium base lampholder for 15W, 25W, 40W, or 60W T10 lamp. Lamp not included. 120V only	AWN, SM units
	PL7	Fluorescent Night Light for 7W, T-4, G23 lamp	4PS, SM, and WAL series
	PL9	Fluorescent Night Light for 9W, T-4, G23 lamp	
	PL13	Fluorescent Night Light for 13W, T-4, GX23 lamp	
		Lamp not included. PL ballast will default to fixture voltage unless specified	
	GCO	Grounded convenience outlet (120V only)	WPM, WM, WAL, UCS and UC Standard on SA, W
	C6P15_	6' Cord and Straight Blade, NEMA 5-15P, 15A (Add Voltage: 1 = 120)	All industrial fixtures
	C6TL15_	6' Cord and Twist-Lock Plug, NEMA L5-15P (120V) NEMA L7-15P (277V), 15A (Add Voltage: 1 = 120, 2 =277)	
	C6TL20_	6' Cord and Twist-Lock Plug, NEMA L5-20P (120V) NEMA L7-20P (277V), 20A (Add Voltage: 1 = 120, 2 =277)	
	F3C_	3-Conductor feed cord, 18ga stranded wire (Add length needed: 5 = 5', 10 = 10', or 15 = 15')	All industrial fixtures
	F4C_	4-Conductor feed cord, 18ga stranded wire (Add length needed: 5 = 5', 10 = 10', or 15 = 15')	
	GLR	Fast blow fuse, fuse amps based on fixture ordered	All fixtures

WIRING OPTIONS

Master/Satellite Wiring Harness

DETAIL FOR 2' x 4' 3-LAMP LUMINAIRES

Adapter plate K. O. for line feed.

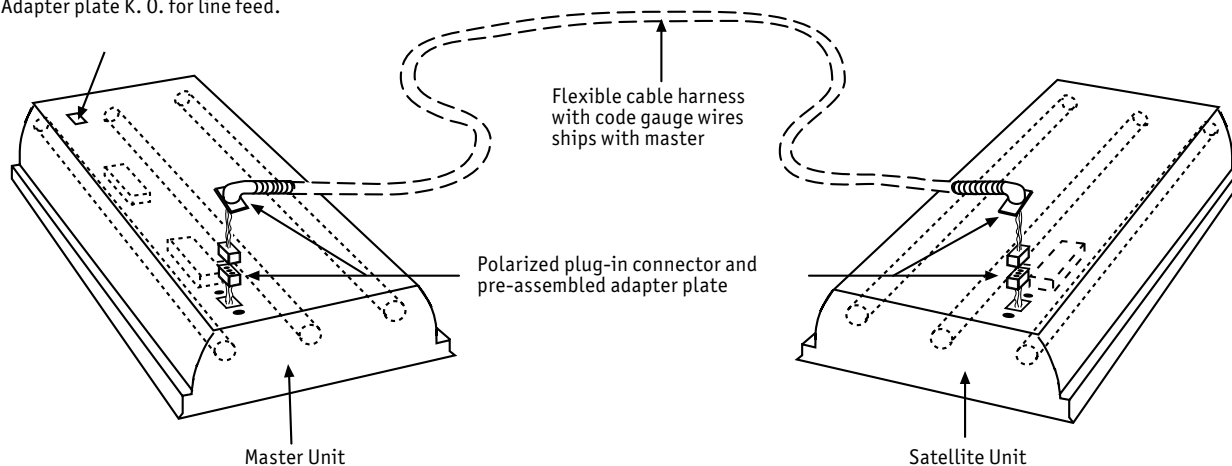

Ballast	Master	Satellite
E, EP	(2) 2-Lamp	(1) 2-Lamp
24E, 24EP	(1) 2-Lamp + (1) 4-Lamp	None

All wired for inboard-outboard

- Master/satellite units bear appropriate UL labels.
- Single units must be ordered to fill odd number layouts.
- Harness may be ordered with any Columbia Lighting 3-Lamp recessed luminaires.
- In master/satellite pairs requiring emergency inverters, UL requires that the inverter be located in the master and power lamps in the master.
- Many programmed start ballasts including all dimming and step dimming ballasts are not suitable for master/satellite applications due to lamp lead length restrictions. See ballast vendor technical data for more information.
- Available on most recessed fixtures. Not available on M46, WT, or AC series.

LAYOUT OPTIONS

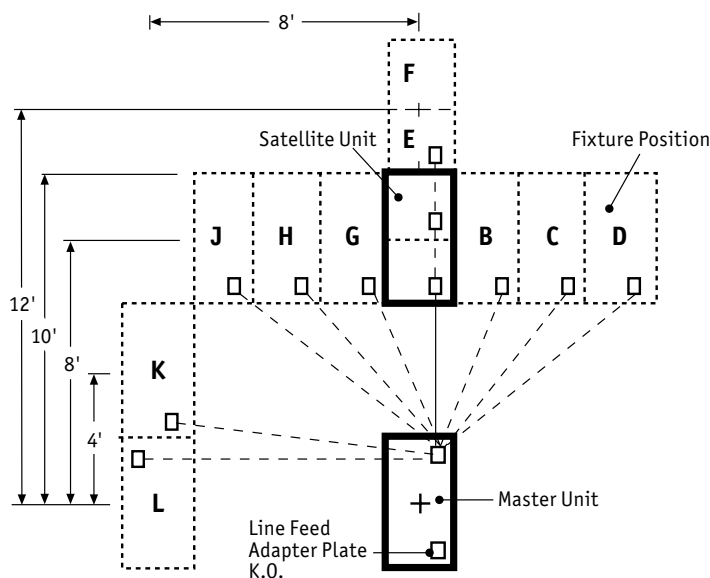

Position	Minimum Length Harness Required
A	6'
B	7'
C	8'
D	9'
E	8'
F	10'
G	7'
H	7'
J	8'
K	9'
L	9'
Harness length must be specified on order.	

Caution: Some electronic ballasts can only be wired with harnesses less than 11' or are not suitable for remote mounting. Consult with ballast manufacturer before specifying.

WIRING OPTIONS

Branch Circuits

PLUG-ON BRANCH CIRCUIT WIRING

Plug-On Branch Circuit Wiring System features complete branch circuit wiring. You supply the feeder; Plug-On does the rest. The system will handle all popular voltage/phase combinations – 2 or 3 wire, 120V, 277V, or 240V, and 3-phase, 4 wire 120/208V or 277/480V-20 amp rating. It is UL listed and combines the following features:

- Available on all continuous row surface mounted fixtures for up to 20 amp circuit runs. Supplied as single or multiple circuit with these fixtures: Surface (PT, AW), Strips (CS, CN, K, LB, KT, SS), Industrials (KL, CSR).
- Available for easy wiring connections for single circuit (BC1), multiple circuits (BC2A, BC2B) or alternating AB or ABC patterns (BC2X, BC3X) for up to 4 circuits in a row.
- May be used with any conventional hanging method – chain, Zip-Tee, slide clamp, stem, or stud.
- Add "G" to option to add a ground wire in harness
- Complete, ready for connection as shipped – no separate parts to misplace. Connectors snap-lock for positive mechanical connection and are color coded for instant identification.
- Carton and channel marked for ballast circuit identity – aids installation, distribution, and maintenance.
- Free factory consulting on coordination of order is recommended to assure proper application.

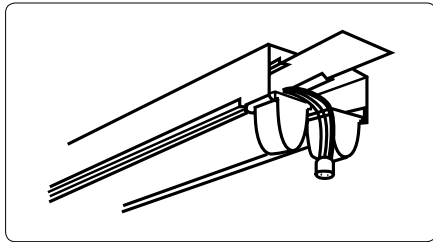

Mount fixture in any economical, familiar manner.

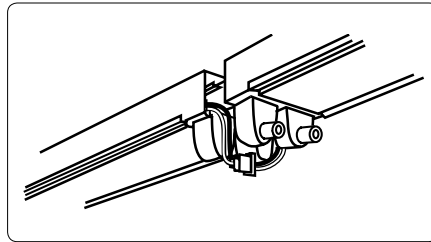

Make electrical connection at same time as mounting next fixture. No need to come back. Power must be off when making connection.

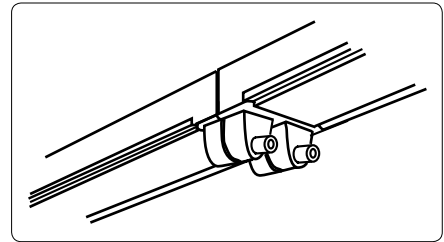

Add lamps and move on to next fixture.

Catalog Number	-Suffix	Description
1 Circuit: 120V-277V (2 Wire)	-BC1	Ballasts connected to black/white wires
2 Circuit: 120V/240V or 120-277V (3 Wire)	-BC2A	Ballasts connected to black/white wires
	-BC2B	Ballasts connected to red/white wires
2 Circuit with 2 ballasts in fixture (3 Wire)	-BC2AB	Black and red wires. Ballast on each plus white. Add L/R option for left/right (in-line) switching
2 Circuit Alternating (3-wire with crossover for A-B-A-B circuit pattern)	-BC2X	Black and red wires. Ballast connected to first position plus white wires
3-Circuit Alternating (4-wire with crossover for A-B-C-A-B-C circuit pattern)	-BC3X	Black, red, and blue wires. Ballast connected to first position plus white wires
3 Circuit: 3 Phase 120V/208V or 277V/480V (4 Wire)	-BC3A	Ballasts connected to black/white wires
	-BC3B	Ballasts connected to red/white wires
	-BC3C	Ballasts connected to blue/white wires
	-BC3D	Ballasts connected to yellow/white wires
4 Circuit (5 Wire)	-BC4A	Ballasts connected to black/white wires
	-BC4B	Ballasts connected to red/white wires
	-BC4C	Ballasts connected to blue/white wires
	-BC4D	Ballasts connected to yellow/white wires

Standard wiring in fixtures with multiple ballasts

In board, out board wiring is standard in fixtures or master/satellite pairs with two or more ballasts and three or more lamps in cross section (except in high bay products).

In tandem-length fixtures lamps side by side will be on the same ballast. Specify L/R option for left/right switching and for most even light distribution when switching fixtures in continuous rows.

LAMP AND PACKAGING OPTIONS

LAMP OPTIONS

Many fixtures can be ordered with lamps pre-installed. Some fixture designs are not available pre-lamped because there is no installation or shipping advantage. Lamp options listed below provide the factory's choice of reputable vendors. Insert lamp option after ballast voltage designation in fixture catalog number. NFO and reduced wattage designations provide lamps meeting applicable NEMA Premium and CEE listing criteria.

Color Rendering Index (CRI) refers to how accurately the lamps phosphor blend reproduces colors compared with a natural source (sunlight). Color temperature refers to how warm (3000°K) or cool (4100°K) the light appears. Candlelight represents an extreme warm (reddish) temperature while sunlight represents an extreme cool (blue-white) temperature.

Please specify vendor's catalog number if a specific vendor, series or lamp feature is required. Reduced wattage lamps may not be suitable for dimming or cold temperature applications. Consult vendor's specification.

LAMP PROFILE (F = FLUORESCENT)	COLOR RENDERING INDEX	COLOR TEMPERATURE	LAMP SHAPE
FO T8 (full wattage) F030 4' T8 reduced wattage (30W) ¹ F028 4' T8 reduced wattage (28W) ¹ (PLUS) F025 4' T8 reduced wattage (25W) ¹ FOH 4' T8 (high lumen) NFO 4' T8, NEMA Premium Full wattage (32W) F5 T5 or T5HO FTT Twin Tube	7 Minimum 75 8 Minimum 82 (T8) or 85 (T5) (Required for NEMA Premium/CEE)	30 3000°K 35 3500°K 41 4100°K	BLANK Straight or Twin Tube U6 U-Lamp 6" Leg Spacing U1 U-Lamp 1 7/8" Leg Spacing

PACKAGING OPTIONS

Products are shipped in individual cartons standard. In fixtures ordered in pallet quantities or greater specify choice of job packaging to ease fixture handling and reduce job site waste disposal. Option available on lensed and parabolic troffers.

PWCS Cartoned, stretch-wrapped to standard pallet.

PNCS Cartoned, stretch-wrapped to narrow pallet.

PW Job pack standard pallet, less cartons with protective outer packaging and stretch-wrapped to 4-way pallet.

PN Job pack narrow, less cartons, with protected outer packaging and stretch-wrapped to 4-way pallet no greater than 24" wide.

¹Not recommended for use with step or full dimming.

TROUBLESHOOTING

FLICKERING LAMPS

1. New lamps need to be seasoned.

In the case of dimming ballasts, most manufacturers recommend 100 burning hours before dimming.

2. Line voltage varies.

Check to see that line voltage current is constant.

3. Air movement across lamp.

Check to make sure that HVAC is not directed across lamps, lowering temperature of lamps.

CYCLING OF BALLAST

1. Line voltage varies.

Check line voltage to make sure constant power is supplied.

2. Replace lamps to verify ballast problem.

3. Insulation covering fixtures.

Check to make sure that fixtures are not covered. Excess heat will cause thermal protector to cycle.

4. Fixtures are mounted on ceiling directly.

Verify that fixtures are designed to be mounted directly to ceiling. If not, an air space must be provided between ceiling and fixtures.

SLOW STARTING

1. Programmed Start ballast versus Instant Start ballast.

Programmed Start ballasts pre-heat the cathode and then ignite lamps. Instant Start ballasts use a high voltage surge to start lamps instantly. Programmed Start ballasts are slower starting but easier on lamps due to pre-heating of cathodes.

2. Line voltage too low.

Check line for correct voltage as required by ballast. (See "Fixtures Do Not Light")

3. Incorrect lamp.

Make sure lamps are compatible with ballast.

4. Low ambient temperatures.

Is temperature above 50°? Some ballasts require higher starting temperatures to start properly.

FIXTURES DO NOT LIGHT

1. Is the power on?

2. Lamp compatibility.

Cross check lamps against ballast designation listed on ballast case. Some energy saving lamps and ballasts are not compatible.

3. Incorrect or loose wiring.

Disconnect power and check all wiring connections.

4. Check fuses if supplied.

Disconnect power before removing. Check with ohmmeter or test equipment. Reinstall and energize.

5. Line voltage low.

Voltage range for 120 volts is 112 minimum and 125 maximum. Voltage range for 277 volts is 255 minimum and 289 maximum.

6. Low ambient temperature.

Fluorescent lamps are hard to start at temperatures below 50°F.

7. Are lamps properly engaged in the lampholders?

Check to make sure that pins are properly engaged.

NOISE

1. Are all components secure?

Check ballast mounting and look for loose fixture components.

2. Is there furniture in the space?

Empty rooms magnify sound, emphasizing the normal operating hum. The sound which seemed so loud in an empty space will normally disappear once the room has been filled with furniture, partitions, and equipment.

3. Is the ballast functioning correctly?

Replace ballast if necessary.

4. What is the sound rating of the ballast?

Verify the ballast's proper sound rating for the environment. If the sound rating is inappropriate, remote mount the ballast or replace it with a ballast with the appropriate sound rating.